

HONEY UNCAPPING TANK

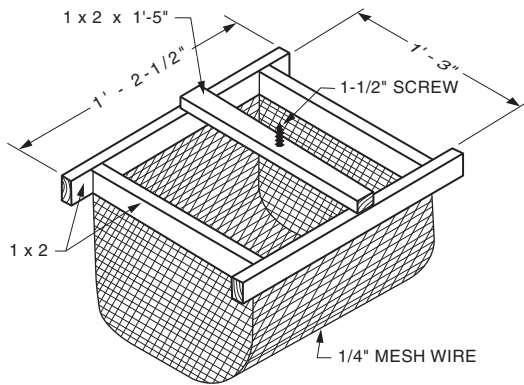

BASKET TO COLLECT WAX CAPPINGS

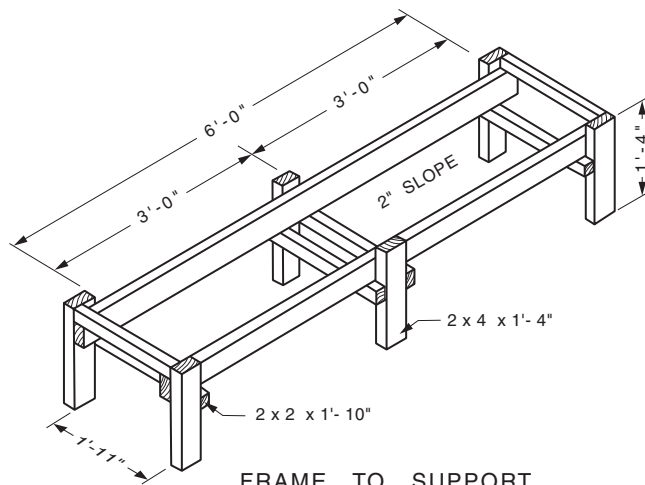

FRAME TO SUPPORT
UNCAPPING TANK

NOTE:

THE UNCAPPING TANK IS USED TO OPEN THE COMBS BEFORE HONEY EXTRACTING. TWO BASKETS MAY BE USED LEAVING APPROXIMATELY 42" TO HANG UNCAPPED COMBS.

MATERIALS:

- FRAME** 2 x 2 x 6'-0" PINE
 2 x 4 x 26'-0" PINE
 1 LB. 10d NAILS
- BASKET** 1 x 2 x 8'-0" PINE
 16-1/2" x 5'-0" x 1/4"
 MESH HDW. CLOTH
- TANK** 4' - 2-3/4" 8' - 6-3/4"
 26 GA. GALVINIZED

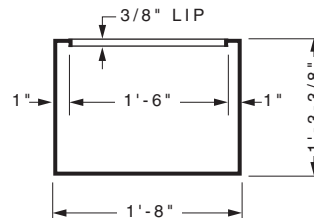

SECTION THRU
CONSTRUCTED
TANK

HONEYCOMB UNCAPPING TANK

SCALE ' NONE

COOPERATIVE EXTENSION WORK IN
AGRICULTURE AND HOME ECONOMICS

AND
UNITED STATES DEPARTMENT OF AGRICULTURE COOPERATING

HONEYCOMB UNCAPPING TANK

USDA ' 80

EX. 6325

SHEET 1 OF 1